



ITEM # _____
 MODEL # _____
 PROJECT NAME _____

SIS #

AIA #



DT1-102001E



McCall Refrigeration specification sheets are available online @ www.mccallrefrigeration.com

DUAL TEMPS (1 SECTION)

Model DT1-102001E

Stainless steel cabinet interior and exterior front, sides, and doors.

Model DT2-202001E

Stainless steel cabinet exterior front, sides, floor and doors. Heavy gauge aluminum cabinet interior with stainless steel floors

Model DT4-402001E

Heavy gauge anodized aluminum cabinet exterior sides. Stainless steel cabinet fronts and doors except for aluminum ends that wrap around front. Heavy gauge aluminum cabinet interior with stainless steel floors.

Standard Features

- Top mounted compressor
- Expansion valve
- Cord and plug (see electrical section)
- R-134a refrigerant (refrigerator)
- R-404A refrigerant (freezer)
- Exterior digital thermometer
- Self-closing cam-lift hinges
- Chrome-plated door handles with security locks
- 6 inch adjustable legs
- Stainless steel shelf supports
- Baked epoxy-coated shelves adjustable on 1 inch centers
- Magnetic door gaskets
- Adjustable doorstops

Approval : _____

SPECIFICATIONS

Cabinet - Cabinets are all metal, inside and out. The top, back, and bottom are made of galvanized steel. In addition, all seams are closed and sealed, with metal edges turned away from the exposed surface. The result is an integrated structural frame. Internal corners are covered to conform to NSF standards. Automatic interior lighting is controlled by a light switch concealed in the door hinge. The cabinet is supported on four 6 inch adjustable steel legs.

Doors - Constructed of metal, refrigerator doors are self-closing and fully insulated. Their cam-lift hinges are chrome-plated and self-lubricating. Hinges also have a safety stop that holds the door open, preventing overswing. Chrome-plated pull handles have built-in cylinder locks. The full-perimeter, magnetic vinyl gaskets are removable without the use of tools. Doors easily lift off, and door perimeters have a built-in, low wattage, and anti-condensate heater. Door openings are protected by an impact-resistant, nonconductive PVC

breaker strip with no exposed screws or fasteners.

Insulation - Cabinet body, doors, and evaporator coil housings are filled with pressure-injected polyurethane foam.

Interior Shelves - Three wire shelves per section are standard. Shelves have a runner spaced 3/4 inch O.C. with two reinforcing bars 8 1/2 inch O.C. Coated with 7 mils of baked-on gray epoxy. The shelves have a saline spray corrosion resistance of 600 hours. Shelves will support 250 pounds each with maximum cabinet load of 800 lbs. They are supported on stainless steel pilasters, and are adjustable on 1 inch centers. All three shelves are interchangeable and can be adjusted without tools or special parts.

Self-Contained Refrigeration - The complete refrigeration assemblies are mounted on top of the cabinet behind a removable hatch cover (2 and 3 section only). One-section has interior evap-

orator coils. Refrigeration components include two hermetically sealed compressors, receiver tanks, the thermostatic expansion valves, thermostatic temperature controls, high-humidity evaporator coils. One-section has electrical condensate evaporator pan. The refrigerator system is balanced to maintain 38°F average internal air temperature. The freezer system is balanced to maintain 0°F average internal air temperature. The air distribution system provides even air flow and temperature control throughout the cabinet. All components are factory installed and tested, and supplied with master power switches, and exterior digital thermometers.

Remote Cabinets - Standard remote units are provided with capped refrigeration lines, expansion valves, solenoid valves, electric condensate evaporators, and temperature control. Condensing units are not included. All other features are the same as self-contained units, except no power cord.

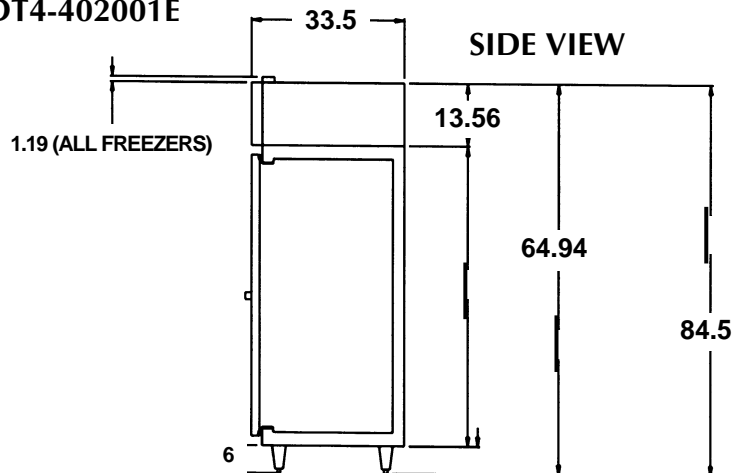
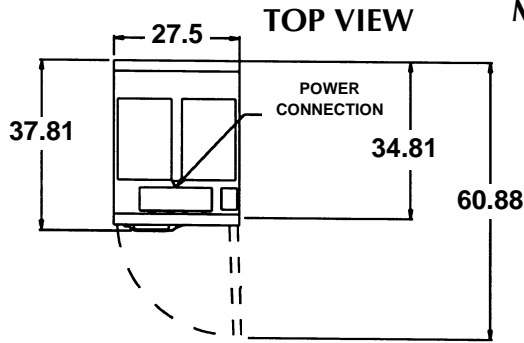

DIMENSIONS

One Section

Net Capacity:	22.4 cu.ft.
Capacity per section:	8.7
Width:	27.5"
Height: including 6" legs	84.5"
Depth: cabinet only - including controls	34.81"
Depth: over hardware - reach-in	37.81"
Depth: over hardware - pass-thru	N/A
Depth: door open 90° - reach-in	60.88"
Depth door open 90° - pass-thru	N/A
Net Door Opening: width	21.25"
Net Door Opening: height - half doors	26.34"
Net Door Opening: height - full door	N/A
Adjustable Shelves	4
Shipping Weight	
Model DT1-102001E	550 lbs.
DT2-202001E	550 lbs.
DT4-402001E	420 lbs.

ELECTRICAL

One Section

Model Number*	DTX-XX2001E***		Glass Doors	
	Refrig.	Frzr.	Refrig.	Frzr.
Compressor HP	1/3	1/4	1/3	1/3
Voltage (60 hz, 1 ph)	115	115	115	115
Total Amperage:	14.2	16	20/20	20/20
BTU/HR**	2400	780	2200	1590
Cord connection -	ANSI 5-20P		Permanent***	

Notes: *X-XX Indicates variation in series

**Based on 90°F ambient and 20°F evaporating temperatures (refrig.) and 90°F ambient and -20°F evaporating temperatures (frzr.).

Specifications subject to change without notice.

Certain options and accessories may affect UL/NSF listing and electrical requirements.

*** Electrical condensate has separate cord connection not to be electrically connected to cabinet.

Bidding Specifications

McCall Dual Temperature Cabinets shall have:

Top mounted compressor. Automatic defrost. Expansion Valve. Hot gas condensate evaporator. Matched and balanced system. Exclusive, Stainless steel front, doors and floor. Self-closing all metal doors with welded and polished corners. Cam-lift hinges with concealed light switches. Adjustable doorstops. Exterior digital thermometer. Chrome-plated door handles with security lock. Stainless steel pilasters adjustable on 1" centers. Three epoxy coated shelves per section. 6" adjustable legs. Master Power Switch. R-134a refrigerant (refrigerator). R-404A refrigerant (freezer). 22.4 cubic ft. capacity. Dimensions: Width=27.5"/Height=84.5"

OPTIONS

Model Suffix	Description	Model Suffix	Description	Model Suffix	Description
01	<input type="checkbox"/> Half height doors.	A	<input type="checkbox"/> Audio visual alarm.		<input type="checkbox"/> Tray slides
GD	<input type="checkbox"/> Hinged glass doors with horizontal 40 watt fluorescent lighting.	P	<input type="checkbox"/> Pass-Thru.		<input type="checkbox"/> Stainless steel shelves.
		R	<input type="checkbox"/> Remote.		<input type="checkbox"/> ___ extra epoxy coated shelves.
					<input type="checkbox"/> Dial thermometer

McCall Refrigeration / 81 West Holly Street / Parsons, TN 38363

Phone (731) 847-5570 / Fax (731) 847-9012 / 1-888-REACH-IN (1-888-732-2446) / www.mccallrefrigeration.com

September 2001 / Printed in U.S.A.