



ITEM # _____
 MODEL # _____
 PROJECT NAME _____

SIS #

AIA #

-10°F REACH-IN FREEZERS (1 AND 2 SECTION)



1-1024UF



2-2045UF



McCall Refrigeration specification sheets are available online @ www.mccallrefrigeration.com

Model 1-1024UF and 1-1045UF

Stainless steel cabinet interior and exterior front, sides and doors.

Model 2-2024UF and 2-2045UF

Stainless steel cabinet exterior front, sides and doors.
 Heavy gauge aluminum cabinet interior with stainless steel floors.

Model 4-4024UF and 4-4045UF

Heavy gauge anodized aluminum cabinet exterior sides.
 Stainless steel cabinet fronts and doors except for aluminum ends that wrap around front.
 Heavy gauge aluminum cabinet interior with stainless steel floors.

Standard Features

- Top mounted compressor and evaporator coil
- Expansion valve
- PSC Evaporator motor relief vent
- Hot gas condensate evaporator
- R-404A refrigerant
- Cord and plug attached (self-contained only)
- Windrunner gradient air displacement process
- Exterior digital thermometer
- Self-closing cam-lift hinges
- Chrome-plated door handles with security locks
- 6 inch adjustable legs
- Baked epoxy-coated shelves adjustable on 1 inch centers
- Concealed light switch
- Stainless steel pilasters
- Adjustable doorstops

Approval : _____

SPECIFICATIONS

Cabinet - Cabinets are all metal, inside and out. The top, back, and bottom are made of galvanized steel. In addition, all seams are closed and sealed, with metal edges turned away from the exposed surface. The result is an integrated structural frame. Internal corners are covered to conform to NSF standards. Automatic interior lighting is controlled by a light switch concealed in the door hinge, except glass door models employ a manual switch.

Doors - Constructed of metal, refrigerator doors are self-closing and fully insulated. Their cam-lift hinges are chrome-plated and self-lubricating. Hinges also have a safety stop that holds the door open, preventing over-swing. Chrome-plated pull handles have built-in cylinder locks. The full-perimeter, magnetic vinyl gaskets are removable without the use of tools. Doors easily lift off, and door perimeters have a built-in, low wattage, and anti-condensate heater. Door openings are protected by an impact-resistant, nonconductive PVC breaker strip with no exposed

screws or fasteners.

Insulation - Cabinet body, doors, and evaporator coil housings are filled with pressure-injected polyurethane foam.

Interior Shelves - Three wire shelves per section are standard. Shelves have a runner spaced 3/4 inch O.C. with two reinforcing bars 8 1/2 inch O.C. Coated with 7 mils of baked-on gray epoxy. The shelves have a saline spray corrosion resistance of 600 hours. Shelves will support 250 pounds each with maximum cabinet load of 800 lbs. They are supported on stainless steel pilasters, and are adjustable on 1 inch centers. All three shelves are interchangeable and can be adjusted without tools or special parts.

Self-Contained Refrigeration - The complete refrigeration assembly is mounted on top of the cabinet behind a removable hatch cover. Refrigeration components include a hermetically sealed compressor, thermostatic

expansion valve, thermostatic temperature control, high-humidity evaporator coil PSC evaporator motor relief vent, and hot gas condensate evaporator. The system is balanced to maintain -10°F average internal air temperature. Windrunner gradient air displacement process provides even air flow and temperature control throughout the cabinet. Relief vent facilitates access to cabinet.

All components are factory installed and tested, and supplied with an attached cord and plug, (self-contained, 115 volts less than 16 amps) master power switch, and exterior digital thermometer.

Remote Cabinets - Standard remote units are provided with capped refrigeration lines, expansion valve, solenoid valve, electric condensate evaporator, and temperature control. Condensing unit is not included. All other features are the same as self-contained units, except power cord.

McCall Refrigeration / 81 West Holly Street / Parsons, TN 38363

Phone (731) 847-5570 / Fax (731) 847-9012 / 1-888-REACH-IN (1-888-732-2446) / www.mccallrefrigeration.com

September 2001 / Printed in U.S.A.

AIA #



Model 1-1024UF
 Model 2-2024UF
 Model 4-4024UF
 Model 1-1045UF
 Model 2-2045UF
 Model 4-4045UF

-10°F REACH-IN FREEZERS (1 AND 2 SECTION)

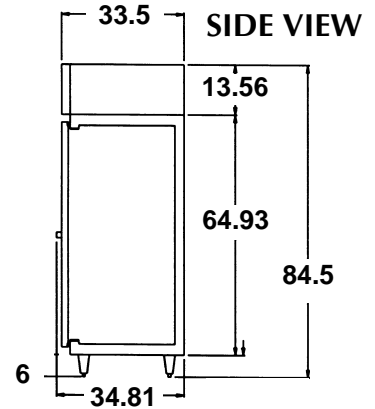
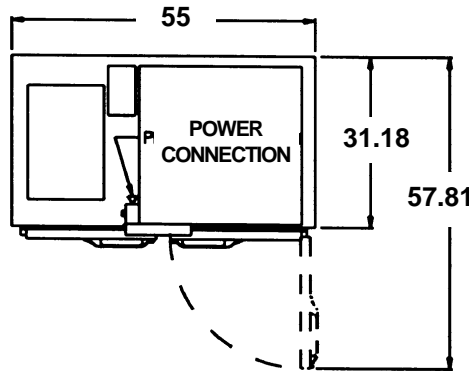
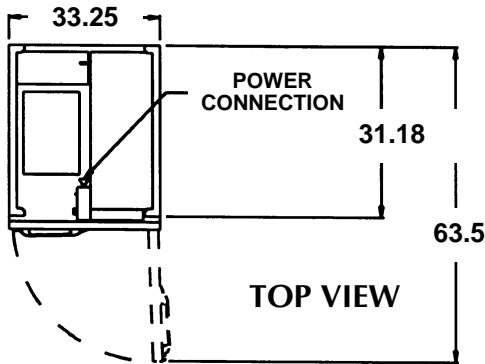

DIMENSIONS

	ONE SECTION	TWO SECTION
Net Capacity:	28.5 cu.ft.	49 cu.ft.
Width:	33.5"	55"
Height: with legs or casters	84.5"	84.5"
Depth: cabinet only - including controls	31.18"	31.18"
Depth: over hardware - reach-in	34.81"	34.81"
Depth: over hardware - pass-thru	38.44"	38.44"
Depth: door open 90° - reach-in	63.5"	57.81"
Net Door Opening: width	21.25"	21.25"
Net Door Opening: height - full doors	58"	58"
Net Door Opening: height - half doors	27"	27"
Adjustable Shelves	3	6
Shipping Weight		
Model 1-1024UF 1-1045UF	500 lbs.	645 lbs.
2-2024UF 2-2045UF	475 lbs.	580 lbs.
4-4024UF 4-4045UF	410 lbs.	530 lbs.

ELECTRICAL

	One Section 24UF	Two Section 45UF****
Base Model Number*		
Compressor HP	1/2	3/4
Voltage (60 hz, 1 ph)	115	115
Total Amperage:	12.4	16
BTU/HR**	1700	2840
Cord connection - ANSI 5-15P		5-20P

Notes: (R) Remote cabinets are equipped for 15 amp permanent connection.
 *First 3 digits omitted.
 **Based on 90°F ambient and -20°F evaporator.
Specifications subject to change without notice.
 Certain options and accessories may affect UL, NSF, CUL listing and electrical requirements.
 ***Metal doors only.

Bidding Specifications

McCall Reach In -10°F Freezer Cabinets shall have:
 Top mounted compressor. Automatic defrost. Expansion Valve. Hot gas condensate evaporator. Matched and balanced system. Maintains average temperature of -10°F. Exclusive Windrunner Gradient Air Displacement Process. Stainless steel front, doors and floor. Self-closing all metal doors with welded and polished corners. Cam-lift hinges with concealed light switches. Adjustable doorstops. Exterior digital thermometer. Chrome-plated door handles with security lock. Stainless steel pilasters adjustable on 1" centers. Three epoxy coated shelves per section. 6" adjustable legs. Master Power Switch. R-404A refrigerant.

OPTIONS

Model Suffix	Description	Model Suffix	Description	Model Suffix	Description
01	<input type="checkbox"/> Half height doors.	A	<input type="checkbox"/> Audio visual alarm.	E	<input type="checkbox"/> Electric condensate evaporator.
C	<input type="checkbox"/> Heavy-duty 6 inch casters (on cord connected models only).				<input type="checkbox"/> Finished back.
					<input type="checkbox"/> Tray slides _____
					<input type="checkbox"/> Stainless steel shelves.
					<input type="checkbox"/> ____ extra epoxy coated shelves.
					<input type="checkbox"/> Left or right door hinge.
					<input type="checkbox"/> 220V

McCall Refrigeration / 81 West Holly Street / Parsons, TN 38363
 Phone (731) 847-5570 / Fax (731) 847-9012 / 1-888-REACH-IN (1-888-732-2446) / www.mccallrefrigeration.com
 September 2001 / Printed in U.S.A.