



**McCall.**

ITEM # \_\_\_\_\_  
MODEL # \_\_\_\_\_  
PROJECT NAME \_\_\_\_\_

SIS #

AIA #

# GLASS DOOR REACH-IN REFRIGERATORS ( 3 SECTION )



**1-1070GD**

## Model 1-1070GD

Stainless steel cabinet interior and exterior front, sides with two pane glass doors.

## Model 2-2070GD

Stainless steel cabinet exterior front, sides and floor with two pane glass doors. Heavy gauge aluminum cabinet interior.

## Model 4-4070GD

Heavy gauge anodized aluminum cabinet exterior sides. Stainless steel cabinet front except for aluminum ends that wrap around front. 2 pane glass doors. Heavy gauge aluminum cabinet interior with stainless steel floors.

### Standard Features

- Top mounted compressor and evaporator coil
- Expansion valve
- Hot gas condensate evaporator
- Windrunner gradient air displacement process
- R-134a refrigerant
- Exterior digital thermometer
- Self-closing spring loaded hinges
- 6 inch adjustable legs
- Baked epoxy-coated shelves adjustable on 1 inch centers



McCall Refrigeration specification sheets are available online @ [www.mccallrefrigeration.com](http://www.mccallrefrigeration.com)

Approval : \_\_\_\_\_

## SPECIFICATIONS

**Cabinet** - Cabinets are all metal, inside and out. The top, back, and bottom are made of galvanized steel. In addition, all seams are closed and sealed, with metal edges turned away from the exposed surface. The result is an integrated structural frame. Internal corners are coved to conform to NSF standards. Automatic interior lighting is controlled by a light switch mounted inside.

**Doors** - Hinged glass doors with horizontal 40 watt fluorescent lighting. (1 section only, 2 & 3 sections vertical.)

**Insulation** - Cabinet body, doors, and evaporator coil housings are filled with pressure-injected polyurethane foam.

**Interior Shelves** - Three wire shelves per sec-

tion are standard. Shelves have a runner spaced 3/4 inch O.C. with two reinforcing bars 8 1/2 inch O.C. Coated with 7 mils of baked-on gray epoxy. The shelves have a saline spray corrosion resistance of 600 hours. Shelves will support 250 pounds each with maximum cabinet load of 800 lbs. They are supported on stainless steel pilasters, and are adjustable on 1 inch centers. All three shelves are interchangeable and can be adjusted without tools or special parts.

**Self-Contained Refrigeration** - The complete refrigeration assembly is mounted on top of the cabinet behind a removable hatch cover. Refrigeration components include a hermetically sealed compressor, thermostatic expansion valve, thermostatic temperature control, high-humidity coated evaporator coil

and hot gas condensate evaporator. The system is balanced to maintain 38°F average internal air temperature. Windrunner gradient air displacement process provides even air flow and temperature control throughout the cabinet. All components are factory installed and tested, and supplied with an attached cord and plug (self-contained, 115 volt only less than 16 amps), master power switch, and exterior digital thermometer.

**Remote Cabinets** - Standard remote units are provided with capped refrigeration lines, expansion valve, solenoid valve, electric condensate evaporator, and temperature control. Condensing unit is not included. All other features are the same as self-contained units, except power cord.

AIA #



Model 1-1070GD  
Model 2-2070GD  
Model 4-4070GD

# GLASS DOOR REACH-IN REFRIGERATORS ( 3 SECTION )

TOP VIEW  
PASS - THRU

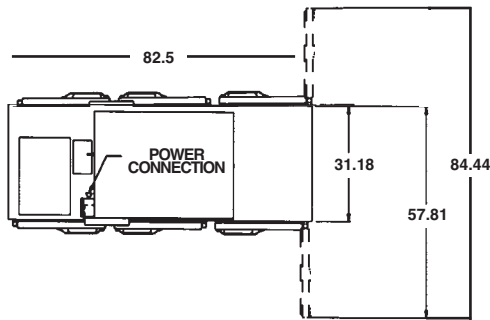

TOP VIEW

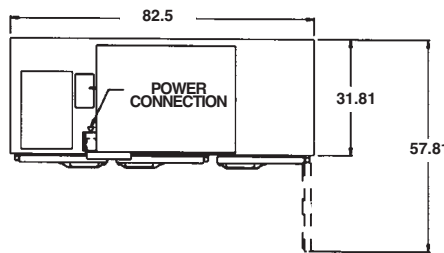

SIDE VIEW

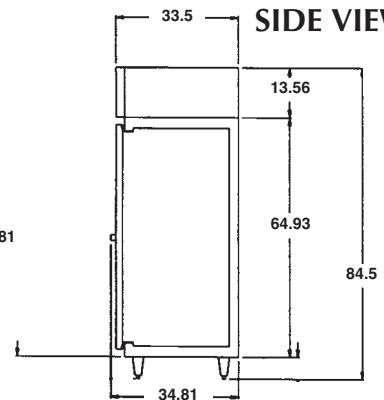

## DIMENSIONS

	Three Section
Net Capacity:	72 cu.ft.
Width: 27.5"	82.5"
Height: with legs or casters	84.5"
Depth: cabinet only - including controls	31.18"
Depth: over hardware - reach-in	34.81"
Depth: over hardware - pass-thru	38.44"
Depth: door open 90° - reach-in	57.81"
Depth: door open 90° - pass-thru	84.44"
Net Door Opening: width	21.25"
Net Door Opening: height - full doors	58"
Net Door Opening: height - half doors	27"
Adjustable Shelves	9
Shipping Weight:	
Model 1-1070GD	815 lbs.
2-2070GD	715 lbs.
4-4070GD	700 lbs.

## ELECTRICAL

	Three Section	Pass Thru
Base Model Number*	70GD	70PGD***
Compressor HP	3/4	3/4
Voltage (60 hz, 1 ph)	208/230	208/230
Total Amperage:	12.5	13.8
BTU/HR**	5220	6240
Electrical connection - ANSI	Perm.	Perm. (3 wire + ground)

**Notes:** (R) Remote cabinets are equipped for permanent connection.

\*First 3 digits omitted.

\*\*Based on 90°F ambient and 20°F evaporating temperature.

**Specifications subject to change without notice.**

Certain options and accessories may affect UL/NSF listing and electrical requirements.

\*\*\*Six (6) half glass or three (3) full glass doors maximum.

## Bidding Specifications

### McCall Glass Door Reach-In Refrigerator Cabinets shall have:

Top mounted compressor. Automatic defrost. Expansion Valve. Hot gas condensate evaporator. Matched and balanced system. Exclusive Windrunner Gradient Air Displacement Process. Stainless steel front, doors and floor. Self-closing hinged glass doors, with fluorescent lights. Adjustable doorstops. Exterior digital thermometer. Stainless steel pilasters adjustable on 1" centers. Three epoxy coated shelves per section. 6" adjustable legs. Master Power Switch. R-134a refrigerant. 72 cubic ft. capacity. Dimensions: Width=82.5"/Height=84.5"

## OPTIONS

Model Suffix	Description
01	<input type="checkbox"/> Half height doors.
C	<input type="checkbox"/> Heavy-duty 6 inch casters (on cord connected models only).
A	<input type="checkbox"/> Audio visual alarm.
P	<input type="checkbox"/> Pass-Thru.
R	<input type="checkbox"/> Remote.

Model Suffix	Description
E	<input type="checkbox"/> Electric condensate evaporator.
	<input type="checkbox"/> Finished back.
	<input type="checkbox"/> Tray slides _____
	<input type="checkbox"/> Stainless steel shelves.
	<input type="checkbox"/> _____ extra epoxy coated shelves.
	<input type="checkbox"/> Left or right door hinge.
	<input type="checkbox"/> _____

McCall Refrigeration / 81 West Holly Street / Parsons, TN 38363

Phone (731) 847-5570 / Fax (731) 847-9012 / 1-888-REACH-IN (1-888-732-2446) / www.mccallrefrigeration.com

October 2003 / Printed in U.S.A.